



Závítníky sadové / Set of hand taps / Satzgewindebohrer / Метчики наборные

Norma Standard Norm Стандарт	MATERIÁL / MATERIAL / MATERIAL / МАТЕРИАЛ													
	MAT	A	B	C	D	E	F	G	H	I	J	K	L	M
ČSN 22 3010	HSS	●	●	◐	●	◐	●	●	◐	◐	◐	○	◐	◐
	NO/CS	●	◐		◐	○	◐	◐	○	○	○		○	○
PN 8/3011	HSS	●	●	◐	●	◐	●	●	◐	◐	◐	○	◐	◐
	NO/CS	●	◐		◐	○	◐	◐	○	○	○		○	○
ČSN 22 3012	HSS	●	●	◐	●	◐	●	●	◐	◐	◐	○	◐	◐
	NO/CS	●	◐		◐	○	◐	◐	○	○	○		○	○
PN 8/3014	HSS	●	●	◐	●	◐	●	●	◐	◐	◐	○	◐	◐
	NO/CS	●	◐		◐	○	◐	◐	○	○	○		○	○
DIN 352	HSS	●	●	◐	●	◐	●	●	◐	◐	◐	○	◐	◐
	NO/CS	●	◐		◐	○	◐	◐	○	○	○		○	○
DIN 2181	HSS	●	●	◐	●	◐	●	●	◐	◐	◐	○	◐	◐
	NO/CS	●	◐		◐	○	◐	◐	○	○	○		○	○
PN 8/3015	HSS	●	●	◐	●	◐	●	●	◐	◐	◐	○	◐	◐
	NO/CS	●	◐		◐	○	◐	◐	○	○	○		○	○
V <sub>c</sub> m/min	HSS	6-10	2-8	2-6	2-6	2-4	2-6	2-4	5-8	6-10	12-18	5-8	10-15	10-15
	NO/CS	4-7	2-5		1-4	1-3	1-4	1-3	2-4	4-7	8-12		5-10	5-10
		1	1	1	1	1	1	1	1, 3	1, 3	1, 3	1, 3	2, 3	3

	INFORMACE - SYMBOLY	INFORMATION - NOTATION	INFORMATIONEN - BILDERE	ИНФОРМАЦИИ - СИМВОЛЫ
NO/CS/WS	nástrojová ocel	Carbon steel	Werkzeugstahl	Инструментальная сталь
HSS	výkonná rychlořezná ocel	High speed steel	Schnellschneidstahl	Сталь скоростной нарезки
HSSE	vysoce výkonná rychlořezná ocel	Super high speed steel	Höher legiertet Schnellschneidstahl	Сверх производительная быстрорежу - щаяся сталь
ČSN	česká norma	Czech standard	Tschechische Norm	Чешский стандарт
PN	podniková norma	Company standard	Betriebsnorm	Стандарт общефабричный
LH	levý závit	Left-hand thread	Gewinde links	Резьба левая
TiN	povlak nitridu titanu	Titanium nitride coating	Titannitrid-Beschichtung	TiN покрытие
N	nitridace	Nitration	Nitrieren	Нитридование
OX	oxidace	Oxidation	Oxidation	Оксидирование
V <sub>c</sub>	řezná rychlost	Cutting speed	Schnittgeschwindigkeit	Скорость нарезки резьбы
	řezná kapalina	Cutting lubrication	Schneidflüssigkeit	Рекомендуемая жидкость
S	počet třískových otvorů	Number of clearance holes	Anzahl Spanlöcher	Количество зубьев в плашке
VA	na nerez	Stainless steel	Rostfreistähle	Нережавейка
	tloušťka plechu	Sheet thickness	Blechstärke	Толщина листа

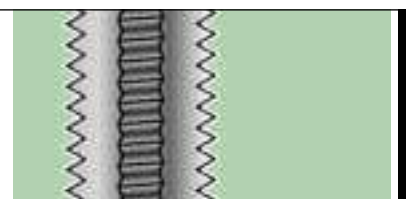

NO

CS

HSS



**BUČOVICE TOOLS**

## Závitníky sadové Set of hand taps Satzgewindebohrer Метчики наборные

M

Metrický závit  
Standard metric thread  
Metrische Regelgewinde  
Метрическая резьба

MF

Jemný metrický závit  
Fine metric thread  
Metrische Feingewinde  
Мелкая метрическая резьба

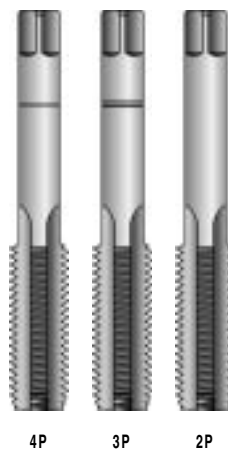
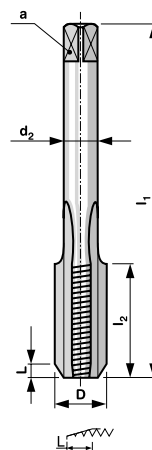
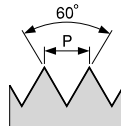
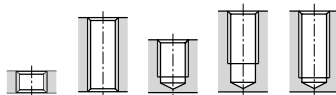

D	P	l <sub>1</sub>	l <sub>2</sub>	d <sub>2</sub>	a		*	code NO/CS	code HSS
M 2	0,4	34	8	2,5	2	1,6	3	110 020	140 020
M 2,2	0,45	34	9	2,8	2,24	1,75	3	110 022	140 022
M 2,5	0,45	34	10	2,8	2,24	2,05	3	110 025	140 025
M 2,5	0,35	28	8	2,8	2,24	2,15	2	110 026	140 026
M 3	0,5	36	10	3,15	2,5	2,5	3	110 030	140 030
M 3	0,35	32	8	3,15	2,5	2,65	2	110 031	140 031
M 3,5	0,6	36	12	3,55	2,8	2,9	3	110 035	140 035
M 3,5	0,35	32	9	3,55	2,8	3,15	2	110 036	140 036
M 4	0,7	41	14	4	3,15	3,3	3	110 040	140 040
M 4	0,5	38	11	4	3,15	3,5	2	110 041	140 041
M 4,5	0,5	38	11	4,5	3,55	4,0	2	110 046	140 046
M 5	0,8	45	16	5	4	4,2	3	110 050	140 050
M 5	0,5	40	11	5	4	4,5	2	110 051	140 051
M 5,5	0,5	40	12	5,6	4,5	5,0	2	110 056	140 056
M 6	1	50	17	4,5	3,55	5,0	3	110 060	140 060
M 6	0,75	44	15	4,5	3,55	5,2	2	110 061	140 061
M 7	1	50	17	5,6	4,5	6,0	3	110 070	140 070
M 7	0,75	44	15	5,6	4,5	6,2	2	110 071	140 071
M 8	1,25	54	22	6	5	6,8	3	110 080	140 080
M 8	1	46	16	6	5	7,0	2	110 081	140 081
M 8	0,75	44	16	6	5	7,2	2	110 082	140 082
M 9	1,25	60	22	7,1	5,6	7,8	3	110 090	140 090
M 9	1	52	17	7,1	5,6	8,0	2	110 091	140 091
M 9	0,75	50	17	7,1	5,6	8,2	2	110 092	140 092
M 10	1,5	63	25	7,1	5,6	8,5	3	110 100	140 100
M 10	1,25	56	18	7,1	5,6	8,8	2	110 101	140 101
M 10	1	56	18	7,1	5,6	9,0	2	110 102	140 102
M 10	0,75	56	18	7,1	5,6	9,2	2	110 103	140 103
M 11	1,5	63	28	8	6,3	9,5	3	110 110	140 110
M 11	1	56	20	8	6,3	10,0	2	110 111	140 111
M 11	0,75	56	20	8	6,3	10,2	2	110 112	140 112
M 12	1,75	70	30	9	7,1	10,2	3	110 120	140 120
M 12	1,5	63	25	9	7,1	10,5	2	110 121	140 121
M 12	1,25	60	22	9	7,1	10,8	2	110 122	140 122
M 12	1	60	22	9	7,1	11,0	2	110 123	140 123
M 14	2	80	30	11	9	12,0	3	110 140	140 140
M 14	1,5	70	28	11	9	12,5	2	110 141	140 141
M 14	1,25	63	25	11	9	12,8	2	110 142	140 142
M 14	1	63	25	11	9	13,0	2	110 143	140 143
M 15	1	70	25	11	9	14,0	2	110 152	140 152
M 16	2	80	35	12,5	10	14,0	3	110 160	140 160
M 16	1,5	70	28	12,5	10	14,5	2	110 161	140 161
M 16	1	70	25	12,5	10	15,0	2	110 162	140 162
M 17	1	70	28	12,5	10	16,0	2	110 171	140 171
M 18	2,5	90	36	14	11,2	15,5	3	110 180	140 180
M 18	1,5	80	32	14	11,2	16,5	2	110 181	140 181
M 18	1	70	28	14	11,2	17,0	2	110 182	140 182
M 20	2,5	90	36	14	11,2	17,5	3	110 200	140 200
M 20	1,5	80	32	14	11,2	18,5	2	110 201	140 201
M 20	1	75	28	14	11,2	19,0	2	110 202	140 202
M 22	2,5	90	40	16	12,5	19,5	3	110 220	140 220
M 22	1,5	80	32	16	12,5	20,5	2	110 221	140 221
M 22	1	75	28	16	12,5	21,0	2	110 222	140 222
M 24	3	100	45	18	14	21,0	3	110 240	140 240
M 24	2	90	36	18	14	22,0	2	110 241	140 241
M 24	1,5	85	32	18	14	22,5	2	110 242	140 242
M 24	1	80	28	18	14	23,0	1	110 243	140 243
M 25	1,5	90	32	18	14	23,5	2	110 252	140 252
M 26	1,5	90	32	18	14	24,5	2	110 262	140 262
M 27	3	100	45	20	16	24	3	110 270	140 270

Materiál: NO; HSS  
Provedení: nebroušený závit  
Závit: pravý, levý - dle požadavku  
Licování: 2N

Material: CS; HSS  
Execution: non-ground thread  
Thread: right-hand, left-hand on request  
Tolerance: 2N

Werkstoff: WS; HSS  
Ausführung: nicht geschliffenes Gewinde  
Gewinde: rechts, links - nach dem Anspruch  
Toleranz: 2N

Материал: NO; HSS  
Изготовлено: нешлифованная резьба  
Резьба: правая, левая - по заказу  
Подгонка: 2N

## Závitníky sadové Set of hand taps Satzgewindebohrer Метчики наборные

M

Metrický závit  
Standard metric thread  
Metrische Regelgewinde  
Метрическая резьба

MF

Jemný metrický závit  
Fine metric thread  
Metrische Feingewinde  
Мелкая метрическая резьба

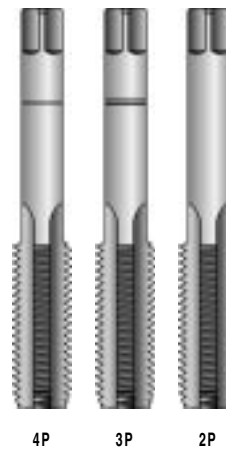
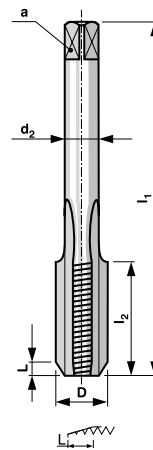
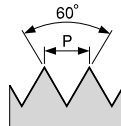
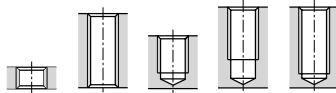

D	P	l <sub>1</sub>	l <sub>2</sub>	d <sub>2</sub>	a		*	code NO/CS	code HSS
M 27	2	90	36	20	16	25	2	110 271	140 271
M 27	1,5	90	32	20	16	25,5	2	110 272	140 272
M 27	1	85	28	20	16	26	1	110 273	140 273
M 28	2	100	36	20	16	26	2	110 281	140 281
M 28	1,5	90	32	20	16	26,5	2	110 282	140 282
M 30	3,5	120	50	20	16	26,5	3	110 300	140 300
M 30	2	100	36	20	16	28	2	110 301	140 301
M 30	1,5	100	32	20	16	28,5	2	110 302	140 302
M 30	1	85	32	20	16	29	1	110 303	140 303

\* kusy v sadě / pcs in set / Stck in Satz / штук в наборе

*Material: NO; HSS  
Provedení: nebroušený závit  
Závit: pravý, levý - dle požadavku  
Licování: 2N*

*Material: CS; HSS  
Execution: non-ground thread  
Thread: right-hand, left-hand on request  
Tolerance: 2N*

*Werkstoff: WS; HSS  
Ausführung: nicht geschliffenes Gewinde  
Gewinde: rechts, links - nach dem Anspruch  
Toleranz: 2N*

*Material: NO; HSS  
Изготовлено: нешлифованная резьба  
Резьба: правая, левая - по заказу  
Подгонка: 2N*

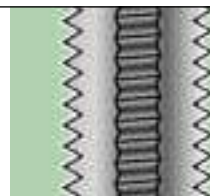

NO

CS

HSS



**BUČOVICE  
TOOLS**

## Závitníky sadové Set of hand taps Satzgewindebohrer Метчики наборные

W

Whitworthův závit  
Whitworth thread  
Whitworth-Gewinde  
Резьба Витворта

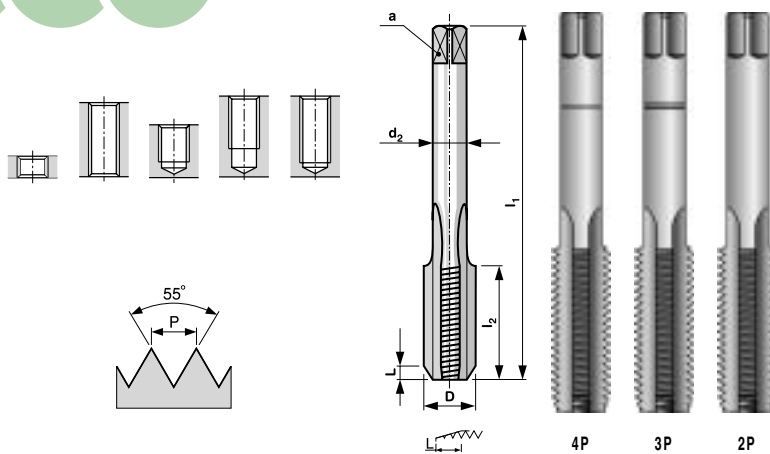

D	z/1"	P	l <sub>1</sub>	l <sub>2</sub>	d <sub>2</sub>	a		*	code NO/CS	code HSS
W 3/32"	48	0,529	34	10	3,15	2,5	1,75	3	111 332	141 332
W 1/8"	40	0,635	37	12	4	3,15	2,4	3	111 180	141 180
W 5/32"	32	0,794	41	14	5	4	3,0	3	111 532	141 532
W 3/16"	24	1,058	44	18	5	4	3,5	3	111 316	141 316
W 7/32"	24	1,058	44	18	5,6	4,5	4,3	3	111 732	141 732
W 1/4"	20	1,270	48	22	6,3	5	4,9	3	111 140	141 140
W 5/16"	18	1,411	51	26	5,6	4,5	6,4	3	111 516	141 516
W 3/8"	16	1,588	60	26	7,1	5,6	7,7	3	111 380	141 380
W 7/16"	14	1,814	60	28	8	6,3	9,1	3	111 716	141 716
W 1/2"	12	2,117	70	32	9	7,1	10,3	3	111 120	141 120
W 9/16"	12	2,117	70	32	9	7,1	11,8	3	111 916	141 916
W 5/8"	11	2,309	80	36	12,5	10	13,25	3	111 580	141 580
W 3/4"	10	2,540	90	40	14	11,2	16,25	3	111 340	141 340
W 7/8"	9	2,822	100	45	18	14	19	3	111 780	141 780
W 1"	8	3,175	110	45	20	16	21,75	3	111 100	141 100

\* kusy v sadě / pcs in set / Stck in Satz / штук в наборе

*Materiál: NO; HSS  
Provedení: nebroušený závit  
Licování: střední*

*Materiál: CS; HSS  
Execution: non-ground thread  
Tolerance: medium*

*Werkstoff: WS; HSS  
Ausführung: nicht geschliffenes  
Gewinde  
Toleranz: mittel*

*Материал: NO; HSS  
Изготовлено: нешлифованная резьба  
Подгонка: средний класс*

NO

CS

HSS



**BUČOVICE TOOLS**

## Závitníky sadové Set of hand taps Satzgewindebohrer Метчики наборные

G

Trubkový závit  
Pipe thread  
Rohrgewinde  
Трубная резьба

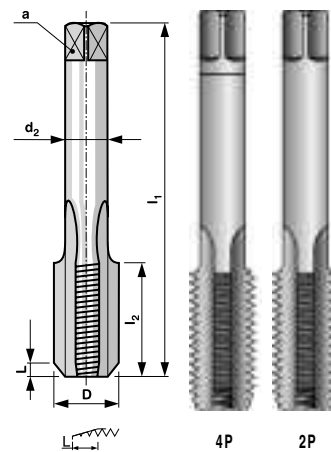
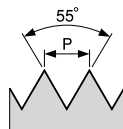
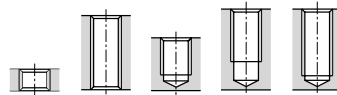

D	z/1"	P	l <sub>1</sub>	l <sub>2</sub>	d <sub>2</sub>	a		*	code NO/CS	code HSS
G 1/16"	28	0,907	52	14	5,6	4,5	6,7	2	112 116	142 116
G 1/8"	28	0,907	59	15	8	6,3	8,8	2	112 180	142 180
G 1/4"	19	1,337	67	19	10	8	11,7	2	112 140	142 140
G 3/8"	19	1,337	75	21	12,5	10	15,2	2	112 380	142 380
G 1/2"	14	1,814	87	26	16	12,5	18,8	2	112 120	142 120
G 5/8"	14	1,814	91	26	18	14	20,75	2	112 580	142 580
G 3/4"	14	1,814	96	28	20	16	24,25	2	112 340	142 340
G 7/8"	14	1,814	102	29	22,4	18	28	2	112 780	142 780
G 1"	11	2,309	109	33	25	20	30,5	2	112 100	142 100

\* kusy v sadě / pcs in set / Stck in Satz / штук в наборе

*Material: NO; HSS*

*Provedení: nebroušený závit*

*Licování: A*

*Material: CS; HSS*

*Execution: non-ground thread*

*Tolerance: A*

*Werkstoff: WS; HSS*

*Ausführung: nicht geschliffenes*

*Gewinde*

*Toleranz: A*

*Material: NO; HSS*

*Изготовлено: нешлифованная резьба*

*Подгонка: A*

# PN 8/3014

NO

CS



**BUČOVICE TOOLS**

## Závitníky sadové Set of hand taps Satzgewindebohrer Метчики наборные

P

Pancéřový závit  
Steel conduit thread  
Stahlpanzerrohr-Gewinde  
Панцирная резьба

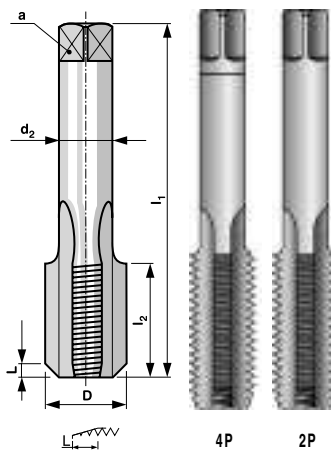
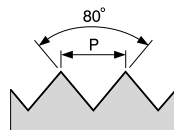
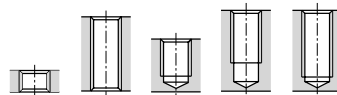

D	z/1"	P	l <sub>1</sub>	l <sub>2</sub>	d <sub>2</sub>	a		*	code NO/CS
P 7	20	1,270	63	28	9	7,1	11,3	2	113 070
P 9	18	1,411	70	28	10	8	13,8	2	113 090
P 11	18	1,411	80	32	12,5	10	17,2	2	113 110
P 13,5	18	1,411	80	32	16	12,5	19,0	2	113 135
P 16	18	1,411	85	32	18	14	21,0	2	113 160
P 21	16	1,588	90	36	20	16	26,75	2	113 210

\* kusy v sadě / pcs in set / Stck in Satz / штук в наборе

*Material: NO*

*Provedení: nebroušený závit*

*Material: CS*

*Execution: non-ground thread*

*Werkstoff: WS*

*Ausführung: nicht geschliffenes*

*Gewinde*

*Material: NO*

*Изготовлено: нешлифованная резьба*

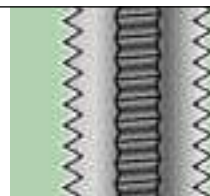

**Závitníky sadové**  
**Set of hand taps**  
**Satzgewindebohrer**  
**Метчики наборные**

**M**

Metrický závit  
 Standard metric thread  
 Metrische Regelgewinde  
 Метрическая резьба

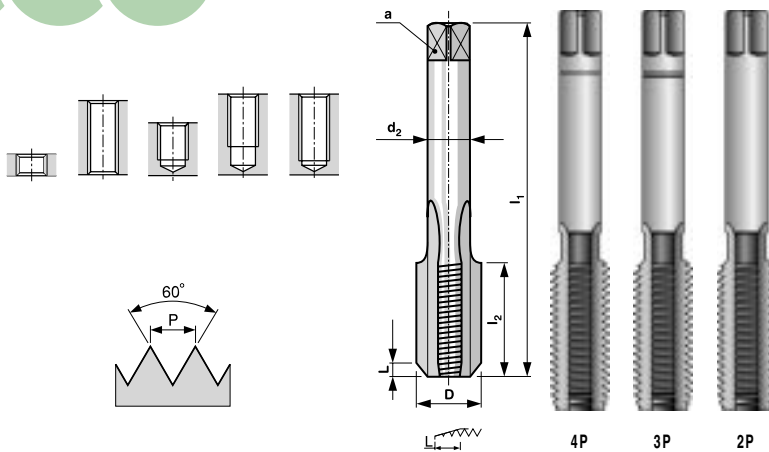

D	P	l <sub>1</sub>	l <sub>2</sub>	d <sub>2</sub>	a		*	code NO/CS	code HSS
M 2	0,4	36	8	2,8	2,1	1,60	3	114 020	144 020
M 2,2	0,45	36	9	2,8	2,1	1,75	3	114 022	144 022
M 2,5	0,45	40	9	2,8	2,1	2,05	3	114 025	144 025
M 3	0,5	40	11	3,5	2,7	2,50	3	114 030	144 030
M 3,5	0,6	45	13	4	3	2,9	3	114 035	144 035
M 4	0,7	45	13	4,5	3,4	3,3	3	114 040	144 040
M 4,5	0,75	50	16	6	4,9	4,0	3	114 045	144 045
M 5	0,8	50	16	6	4,9	4,2	3	114 050	144 050
M 6	1	50	19	6	4,9	5,0	3	114 060	144 060
M 7	1	50	19	6	4,9	6,0	3	114 070	144 070
M 8	1,25	56	22	6	4,9	6,8	3	114 080	144 080
M 9	1,25	63	22	7	5,5	7,8	3	114 090	144 090
M 10	1,5	70	24	7	5,5	8,5	3	114 100	144 100
M 11	1,5	70	24	8	6,2	9,5	3	114 110	144 110
M 12	1,75	75	29	9	7	10,2	3	114 120	144 120
M 14	2	80	30	11	9	12,0	3	114 140	144 140
M 16	2	80	32	12	9	14,0	3	114 160	144 160
M 18	2,5	95	40	14	11	15,5	3	114 180	144 180
M 20	2,5	95	40	16	12	17,5	3	114 200	144 200
M 22	2,5	100	40	18	14,5	19,5	3	114 220	144 220
M 24	3	110	50	18	14,5	21,0	3	114 240	144 240
M 27	3	110	50	20	16	24	3	114 270	144 270
M 30	3,5	125	56	22	18	26,5	3	114 300	144 300

\* kusy v sadě / pcs in set / Stck in Satz / штук в наборе

*Materiál: NO; HSS  
 Provedení: nebroušený závit  
 Závit: pravý, levý - dle požadavku  
 Licování: 2N*

*Material: CS; HSS  
 Execution: non-ground thread  
 Thread: right-hand, left-hand - on request  
 Tolerance: 2N*

*Werkstoff: WS; HSS  
 Ausführung: nicht geschliffenes Gewinde  
 Gewinde: rechts, links - nach dem Anspruch  
 Toleranz: 2N*

*Материал: NO; HSS  
 Изготовлено: нешлифованная резьба  
 Резьба: правая, левая - по заказу  
 Подгонка: 2N*

## Závitníky sadové Set of hand taps Satzgewindebohrer Метчики наборные

MF

Jemný metrický závit  
Fine metric thread  
Metrische Feingewinde  
Мелкая метрическая резьба

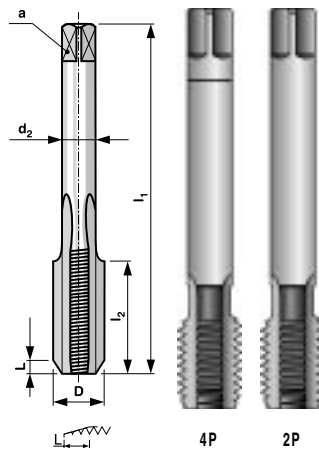
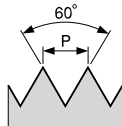
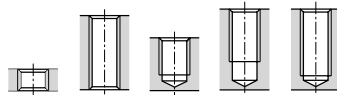

D	P	l <sub>1</sub>	l <sub>2</sub>	d <sub>2</sub>	a		*	code NO/CS	code HSS
M 2,5	0,35	40	9	2,8	2,1	2,15	2	114 026	144 026
M 3	0,35	40	9	3,5	2,7	2,65	2	114 031	144 031
M 3,5	0,35	45	10	4,0	3,0	3,15	2	114 036	144 036
M 4	0,5	45	10	4,5	3,4	3,50	2	114 041	144 041
M 4,5	0,5	50	12	6,0	4,9	4,0	2	114 046	144 046
M 5	0,5	50	12	6,0	4,9	4,5	2	114 051	144 051
M 5,5	0,5	50	12	6,0	4,9	5,0	2	114 056	144 056
M 6	0,75	50	14	6,0	4,9	5,2	2	114 061	144 061
M 7	0,75	50	14	6,0	4,9	6,2	2	114 071	144 071
M 8	1	56	22	6,0	4,9	7,0	2	114 081	144 081
M 8	0,75	50	19	6,0	4,9	7,2	2	114 082	144 082
M 9	1	63	22	7,0	5,5	8,0	2	114 091	144 091
M 9	0,75	56	19	7,0	5,5	8,2	2	114 092	144 092
M 10	1,25	70	24	7,0	5,5	8,8	2	114 101	144 101
M 10	1	63	20	7,0	5,5	9,0	2	114 102	144 102
M 10	0,75	63	20	7,0	5,5	9,2	2	114 103	144 103
M 11	1	63	20	8,0	6,2	10,0	2	114 111	144 111
M 11	0,75	63	20	8,0	6,2	10,2	2	114 112	144 112
M 12	1,5	70	22	9,0	7,0	10,5	2	114 121	144 121
M 12	1,25	70	22	9,0	7,0	10,8	2	114 122	144 122
M 12	1	70	22	9,0	7,0	11,0	2	114 123	144 123
M 14	1,5	70	22	11	9,0	12,5	2	114 141	144 141
M 14	1,25	70	22	11	9,0	12,8	2	114 142	144 142
M 14	1	70	22	11	9,0	13,0	2	114 143	144 143
M 15	1	70	22	12	9,0	14,0	2	114 152	144 152
M 16	1,5	70	22	12	9,0	14,5	2	114 161	144 161
M 16	1	70	22	12	9,0	15,0	2	114 162	144 162
M 17	1	70	22	12	9,0	16,0	2	114 171	144 171
M 18	1,5	80	22	14	11,0	16,5	2	114 181	144 181
M 18	1	80	22	14	11,0	17,0	2	114 182	144 182
M 20	1,5	80	22	16	12,0	18,5	2	114 201	144 201
M 20	1	80	22	16	12,0	19,0	2	114 202	144 202
M 22	1,5	80	22	18	14,5	20,5	2	114 221	144 221
M 22	1	80	22	18	14,5	21,0	2	114 222	144 222
M 24	2	90	22	18	14,5	22,0	2	114 241	144 241
M 24	1,5	90	22	18	14,5	22,5	2	114 242	144 242
M 24	1	90	22	18	14,5	23,0	2	114 243	144 243
M 25	1,5	90	22	18	14,5	23,5	2	114 252	144 252
M 26	1,5	90	22	18	14,5	24,5	2	114 262	144 262
M 27	2	90	22	20	16	25	2	114 271	144 271
M 27	1,5	90	22	20	16	25,5	2	114 272	144 272
M 27	1	90	22	20	16	26	2	114 273	144 273
M 28	2	90	22	20	16	26	2	114 281	144 281
M 28	1,5	90	22	20	16	26,5	2	114 282	144 282
M 30	2	90	22	22	18	28	2	114 301	144 301
M 30	1,5	90	22	22	18	28,5	2	114 302	144 302
M 30	1	90	22	22	18	29	2	114 303	144 303

\* kusy v sadě / pcs in set / Stck in Satz / штук в наборе

**Material:** NO; HSS  
**Provedení:** nebroušený závit  
**Závit:** pravý, levý - dle požadavku  
**Licování:** 2N

**Material:** CS; HSS  
**Execution:** non-ground thread  
**Thread:** right-hand, left-hand - on request  
**Tolerance:** 2N

**Werkstoff:** WS; HSS  
**Ausführung:** nicht geschliffenes Gewinde  
**Gewinde:** rechts, links - nach dem Anspruch  
**Toleranz:** 2N

**Material:** NO; HSS  
**Изготовлено:** нешлифованная резьба  
**Резьба:** правая, левая - по заказу  
**Подгонка:** 2N

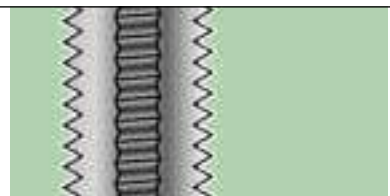

**Závitníky sadové**  
**Set of hand taps**  
**Satzgewindebohrer**  
**Метчики наборные**

**UNC**

Unifikovaný hrubý závit  
 Unified coarse thread  
 Unified-Grobgewinde  
 Унифицированная чёрная резьба

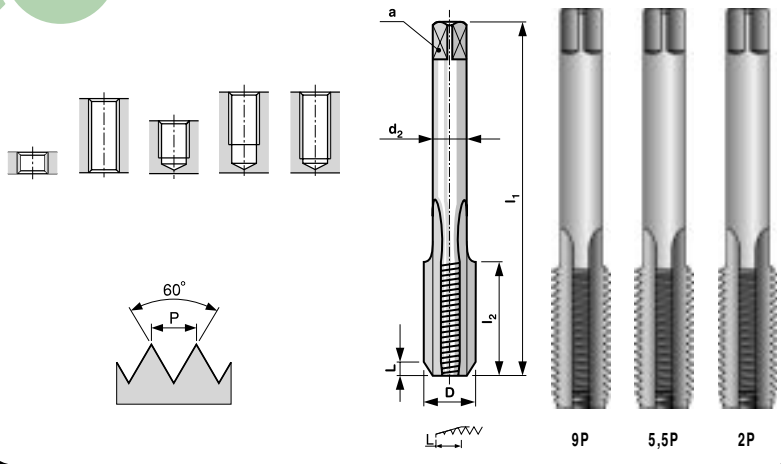

D	z/1"	P	l <sub>1</sub>	l <sub>2</sub>	d <sub>2</sub>	a		*	code NO/CS
4	40	0,635	48	11	3,15	2,5	2,3	3	115 004
5	40	0,635	48	11	3,15	2,5	2,6	3	115 005
6	32	0,794	50	13	3,55	2,8	2,85	3	115 006
8	32	0,794	53	13	4,5	3,55	3,5	3	115 008
10	24	1,058	58	16	5	4	3,9	3	115 010
12	24	1,058	62	17	5,6	4,5	4,5	3	115 012
1/4	20	1,270	66	19	6,3	5	5,1	3	115 140
5/16	18	1,411	72	22	8	6,3	6,6	3	115 516
3/8	16	1,588	78	24	10	8	8,0	3	115 380
7/16	14	1,814	85	25	8	6,3	9,4	3	115 716
1/2	13	1,954	89	29	9	7,1	10,5	3	115 120
9/16	12	2,117	95	30	11,2	9	12,0	3	115 916
5/8	11	2,309	102	32	12,5	10	13,5	3	115 580
3/4	10	2,540	112	37	14	11,2	16,5	3	115 340
7/8	9	2,822	118	38	16	12,5	19,5	3	115 780
1	8	3,175	130	45	18	14	22,25	3	115 100

\* kusy v sadě / pcs in set / Stck in Satz / штук в наборе

*Materiál: NO*  
*Provedení: nebroušený závit*  
*Licování: 2B*

*Materiál: CS*  
*Execution: non-ground thread*  
*Tolerance: 2B*

*Werkstoff: WS*  
*Ausführung: nicht geschliffenes Gewinde*  
*Toleranz: 2B*

*Материал: NO*  
*Изготовлено: нешлифованная резьба*  
*Подгонка: 2B*

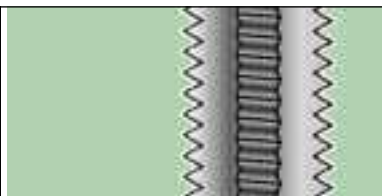



### Závitníky sadové Set of hand taps Satzgewindebohrer Метчики наборные

## UNC

Unifikovaný hrubý závit  
Unified coarse thread  
Unified-Grobgewinde  
Унифицированная чёрная резьба

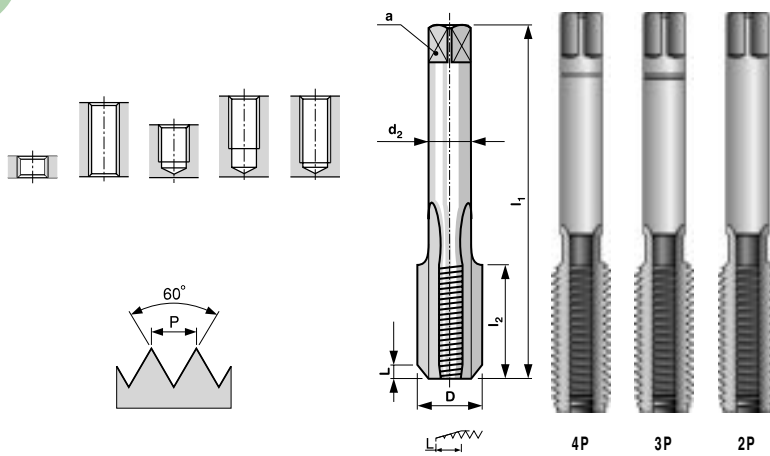

D	z/1"	P	l <sub>1</sub>	l <sub>2</sub>	d <sub>2</sub>	a		*	code HSS
4	40	0,635	40	11	3,5	2,7	2,2	3	145 004
5	40	0,635	40	11	3,5	2,7	2,6	3	145 005
6	32	0,794	45	12	4	3	2,85	3	145 006
8	32	0,794	45	13	4,5	3,4	3,5	3	145 008
10	24	1,058	50	16	6	4,9	3,9	3	145 010
12	24	1,058	50	16	6	4,9	4,5	3	145 012
1/4	20	1,270	50	19	6	4,9	5,2	3	145 140
5/16	18	1,411	53	22	6	4,9	6,6	3	145 516
3/8	16	1,588	70	24	7	5,5	8,0	3	145 380
7/16	14	1,814	70	24	8	6,2	9,4	3	145 716
1/2	13	1,954	75	28	9	7	10,75	3	145 120
9/16	12	2,117	80	30	11	9	12,25	3	145 916
5/8	11	2,309	80	32	12	9	13,5	3	145 580
3/4	10	2,540	95	34	14	11	16,5	3	145 340
7/8	9	2,822	100	34	18	14,5	19,5	3	145 780
1	8	3,175	110	38	18	14,5	22,25	3	145 100

\* kusy v sadě / pcs in set / Stck in Satz / штук в наборе

*Materiál: HSS  
Provedení: nebroušený závit  
Licování: 2B*

*Material: HSS  
Execution: non-ground thread  
Tolerance: 2B*

*Werkstoff: HSS  
Ausführung: nicht geschliffenes  
Gewinde  
Toleranz: 2B*

*Материал: HSS  
Изготовлено:  
нешлифованная резьба  
Подгонка: 2B*

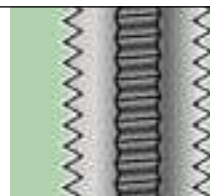

**Závitníky sadové**  
**Set of hand taps**  
**Satzgewindebohrer**  
**Метчики наборные**

**UNF**

Unifikovaný jemný závit  
Unified fine thread  
Unified-Feingewinde  
Унифицированная мелкая резьба

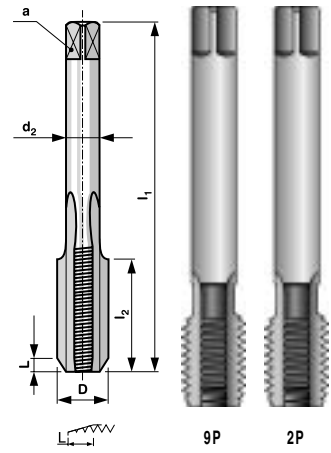
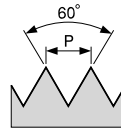
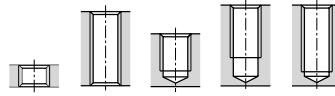

D	z/1"	P	l <sub>1</sub>	l <sub>2</sub>	d <sub>2</sub>	a		*	code NO/CS
4	48	0,529	48	11	3,15	2,5	2,4	2	116 004
5	44	0,577	48	11	3,15	2,5	2,7	2	116 005
6	40	0,635	50	13	3,55	2,8	3,0	2	116 006
8	36	0,706	53	13	4,5	3,55	3,5	2	116 008
10	32	0,794	58	16	5	4	4,1	2	116 010
12	28	0,907	62	17	5,6	4,5	4,7	2	116 012
1/4	28	0,907	66	19	6,3	5	5,5	2	116 140
5/16	24	1,058	72	22	8	6,3	6,9	2	116 516
3/8	24	1,058	78	24	10	8	8,5	2	116 380
7/16	20	1,270	82	22	8	6,3	9,9	2	116 716
1/2	20	1,270	84	24	9	7,1	11,5	2	116 120
9/16	18	1,411	90	25	11,2	9	13,0	2	116 916
5/8	18	1,411	95	25	12,5	10	14,5	2	116 580
3/4	16	1,588	104	29	14	11,2	17,5	2	116 340
7/8	14	1,814	113	33	16	12,5	20,25	2	116 780
1	12	2,117	120	35	18	14	23,25	2	116 100

\* kusy v sadě / pcs in set / Stck in Satz / штук в наборе

*Materiál: NO*  
*Provedení: nebroušený závit*  
*Licování: 2B*

*Materiál: CS*  
*Execution: non-ground thread*  
*Tolerance: 2B*

*Werkstoff: WS*  
*Ausführung: nicht geschliffenes Gewinde*  
*Toleranz: 2B*

*Материал: NO*  
*Изготовлено: нешлифованная резьба*  
*Подгонка: 2B*

### Závitníky sadové Set of hand taps Satzgewindebohrer Метчики наборные

## UNF

Unifikovaný jemný závit  
Unified fine thread  
Unified-Feingewinde  
Унифицированная мелкая резьба

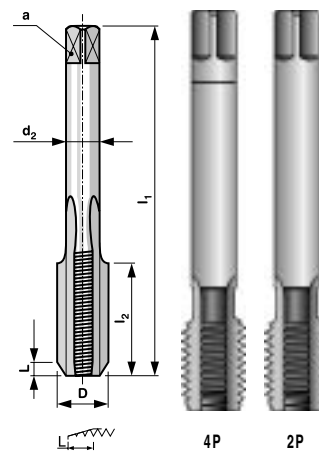
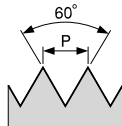
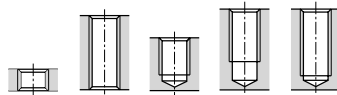

D	z/1"	P	l <sub>1</sub>	l <sub>2</sub>	d <sub>2</sub>	a		*	code HSS
5	44	0,577	40	9	3,5	2,7	2,7	2	146 005
6	40	0,635	45	10	4	3	3,0	2	146 006
8	36	0,706	45	10	4,5	3,4	3,5	2	146 008
10	32	0,794	50	12	6	4,9	4,1	2	146 010
12	28	0,907	50	12	6	4,9	4,65	2	146 012
1/4	28	0,907	50	14	6	4,9	5,5	2	146 140
5/16	24	1,058	56	22	6	4,9	6,9	2	146 516
3/8	24	1,058	63	20	7	5,5	8,5	2	146 380
7/16	20	1,270	63	20	8	6,2	9,9	2	146 716
1/2	20	1,270	70	22	9	7	11,5	2	146 120
9/16	18	1,411	70	22	11	9	12,9	2	146 916
5/8	18	1,411	70	22	12	9	14,5	2	146 580
3/4	16	1,588	80	22	14	11	17,5	2	146 340
7/8	14	1,814	80	22	18	14,5	20,5	2	146 780
1	12	2,117	80	22	18	14,5	23,25	2	146 100

\* kusy v sadě / pcs in set / Stck in Satz / штук в наборе

*Materiál: HSS  
Provedení: nebroušený závit  
Licování: 2B*

*Material: HSS  
Execution: non-ground thread  
Tolerance: 2B*

*Werkstoff: HSS  
Ausführung: nicht geschliffenes  
Gewinde  
Toleranz: 2B*

*Материал: HSS  
Изготовлено:  
нешлифованная резьба  
Подгонка: 2B*

